



SUA-110H3-x-S221

COLOR :

Black: B

White : W

SPECIFICATIONS

Electrical:

- 1.Contact Resistance: 30 milliohms Max
- 2.Dielectric Withstanding Voltage: 500 V AC AT Sec Level
- 3.Insulation Resistance: 1,000 MEGA ohms Min

Mechanical:

- 1.Connector Mate and Unmate Force
Mate force: 3.57 kgf (Max)
Unmate force: 1.02 kgf (Min)

Material:

- 1.Housing: PBT, UL 94V-0 ,RATED
- 2.Contact: Brass
- 3.Shell: Brass

Finish:

- 1.Contact: Plated Gold in Mating Area ;
Tin Plated on Solder Balls
Nickel under plated overall
- 2.Shell: Nickel under Plated surface layer

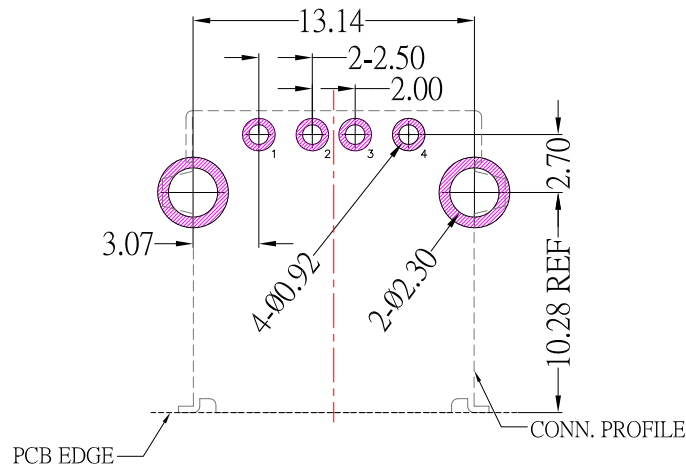
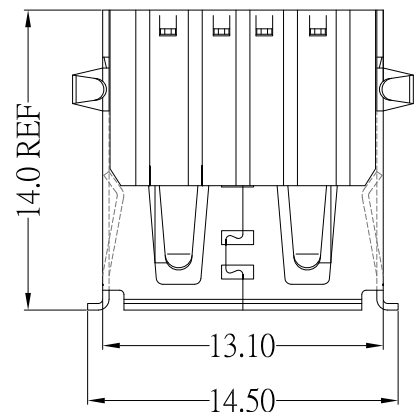

P.C.B LAYOUT MOUNTING PATTERN(TOP VIEW)

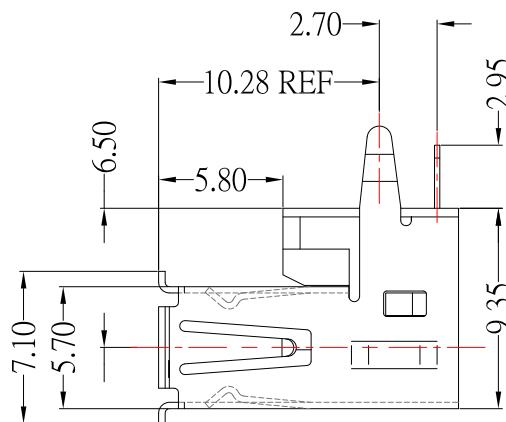
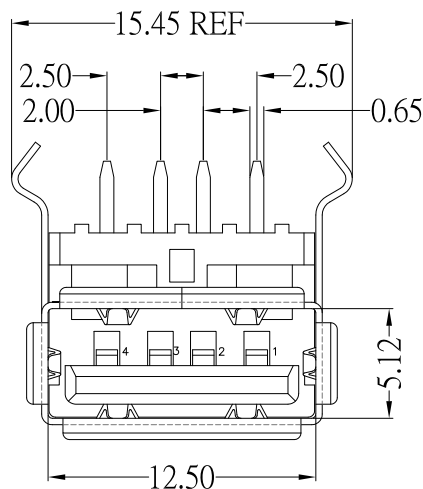

東莞市高迪電子有限公司
DONG GUAN GAO DI ELECTRONICS CO., LTD

TOLERANCE UNLESS OTHERWISE STATED:
Up to 5 ±0.2
Above 5 ~ 15 ±0.3
Above 15 ~ 30 ±0.4
Above 30 ~ 50 ±0.5
Angle ±0.3°

3RD. ANGEL'S

UNITS MM

DRAWN BY:	DATE	MAT'L	TITLE	CONNECTOR
Jack Lu	06/13/14		MODLE	USB AM 90 度 DIP
CHECKED BY:	DATE	FINISH	DWG NO.	SUA-110H3-x-S221
Jacky Chen	06/13/14	SCALE 1 : 1	PART NO.	SUA-110H3-x-S221
APPROVED BY:	DATE	SHEET NO.	1 of 1	SIZE A4
Tony Kao	06/13/14			VER R1

1	更新材質	Jack	061314
ITEM NO.	DESCRIPTION	DRAWN	DATE